

500

561.52241  
314.21083  
311.21007

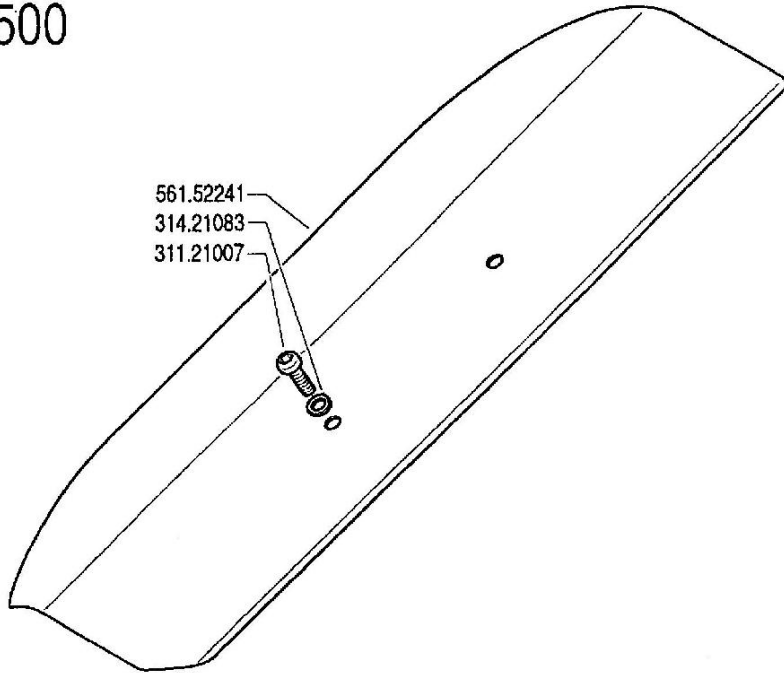

510 - 520 - 530 - 530S ★ - 530S2 ★

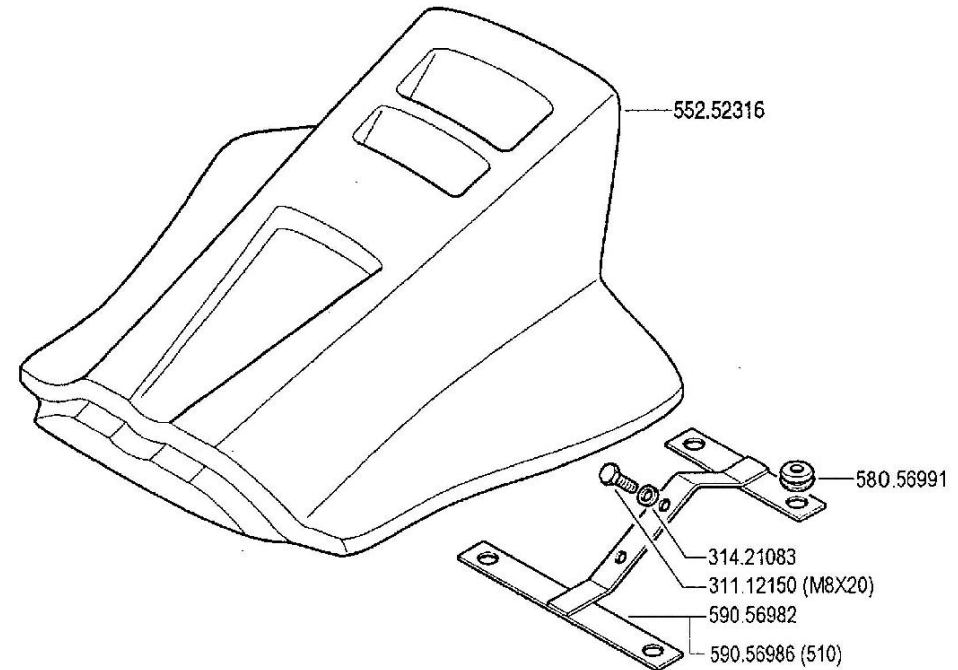

(15 LD 315 / 350) 312.41100  
312.41080  
(15 LD 315 / 350) 314.11104  
314.11084

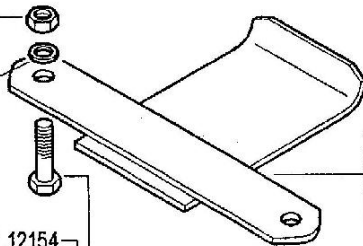

(M8x40) 311.12154  
(15 LD 315 / 350) (M10x40) 311.12213

561.56119 ★ (ACT 280 / 340)  
590.56051 (15 LD 315 / 350)  
590.56089 (HONDA Gx120 ★ - Gx160 - Gx200)  
590.56111 (Yanmar L100 AE)

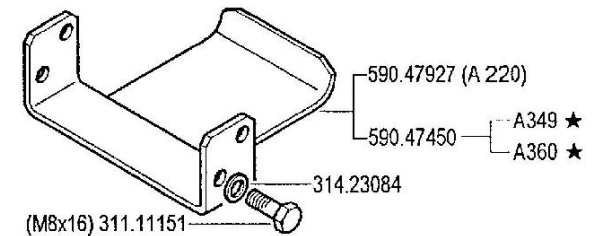
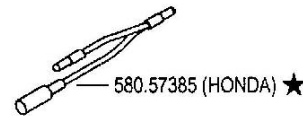

**FERRARI**

500 serie 95

BODY  
CARROCERIA

CARROZZERIA

CARROSSERIE  
KAROSSERIE

DALLA MACCHINA  
DE LA MAQUINA  
DE LA MACHINE  
FROM THE MACHINE  
AB DER MASCHINE

★N

AGGIORNAMENTO  
REVISION  
MISE A JOUR  
APLAZAMIENTO  
ANPASSUNG

01

Rev.  
4

10/2001

ZENNE

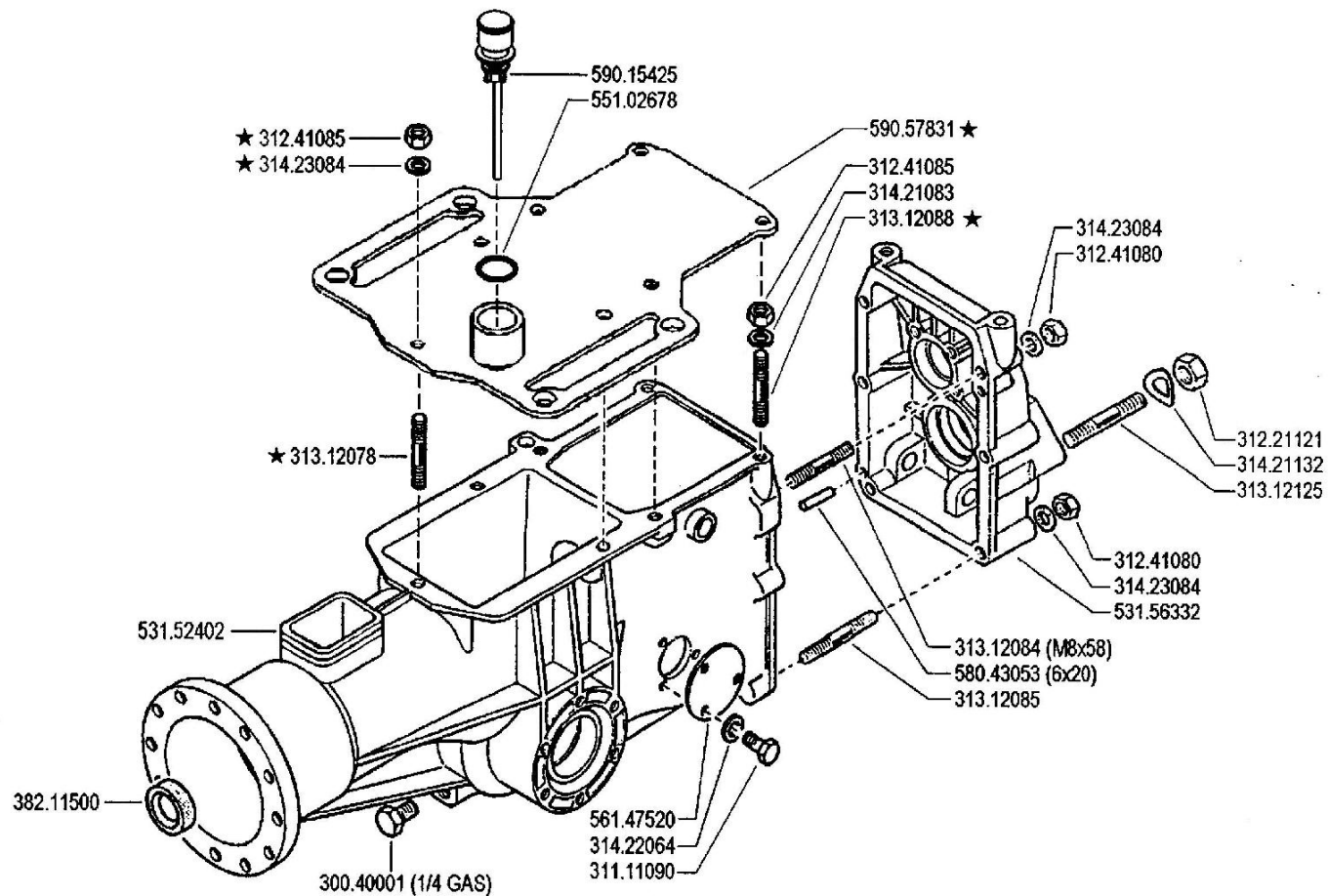

**FERRARI**

**500** serie **95**

**SCATOLA CAMBIO (530S2)**

GEARBOX  
CAJA DE CAMBIO

BOITE DE VITESSES  
WECHSELGETRIEBE

★

DALLA MACCHINA  
DE LA MAQUINA  
DE LA MACHINE  
FROM THE MACHINE  
AB DER MASCHINE

ALLA MACCHINA  
A LA MAQUINA  
A LA MACHINE  
TO THE MACHINE  
BIS MASCHINE

**03 B 0**

Rev.

N.

721207  
721255

721222

1/2004

2/2004

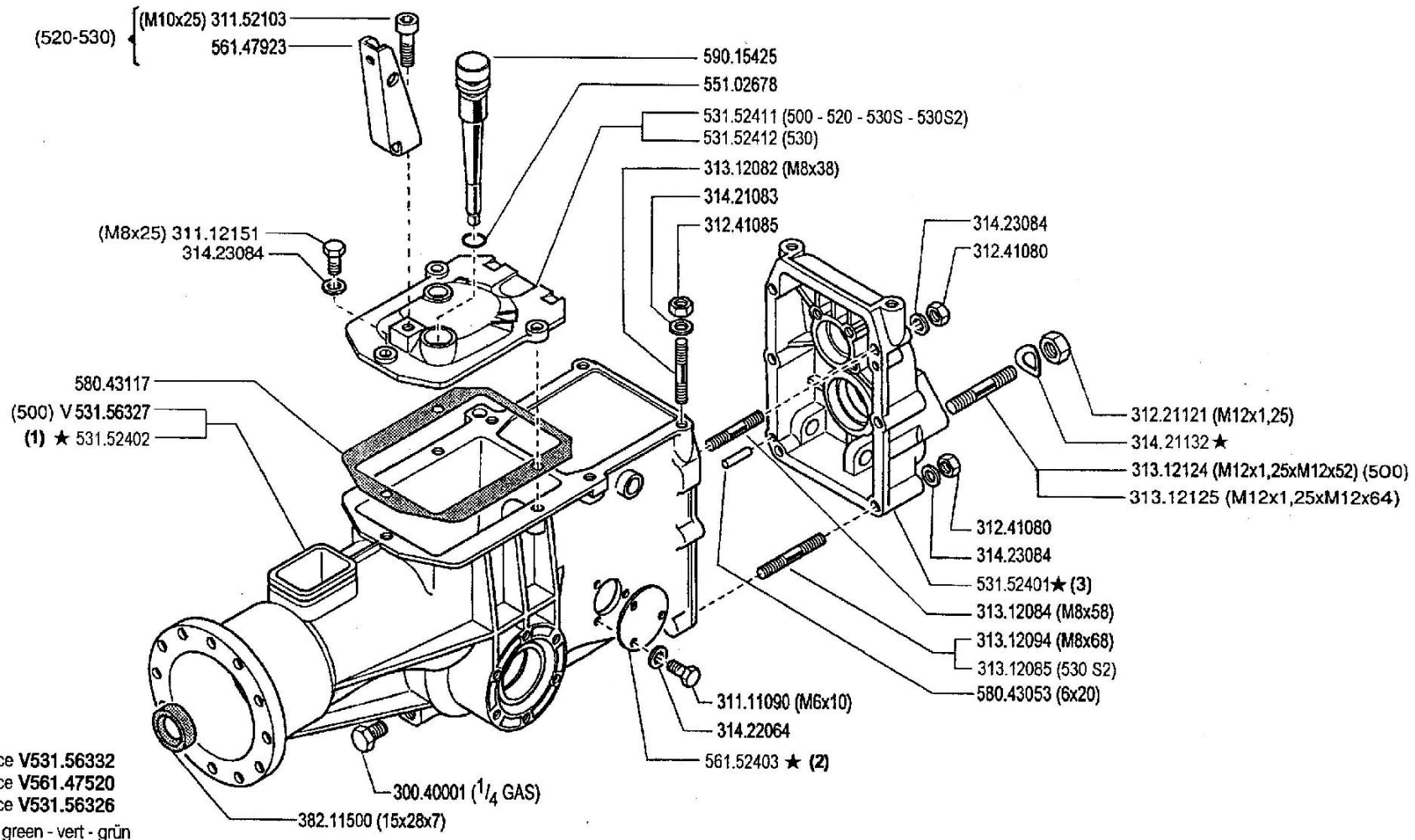

(3) sostituisce V531.56332  
(2) sostituisce V561.47520  
(1) sostituisce V531.56326  
V = verde - green - vert - grün

**FERRARI**

**500** serie 95

**SCATOLA CAMBIO (500 - 520 - 530 - 530S - 530S2)**

GEARBOX  
CAJA DE CAMBIO

BOITE DE VITESSES  
WECHSELGETRIEBE

DALLA MACCHINA  
DE LA MAQUINA  
FROM THE MACHINE  
AB DER MASCHINE

AGGIORNAMENTO
REVISION
MISE A JOUR
APLAZAMIENTO
ANPASSUNG

**03**

Rev.  
**1**

**12/2002**

★ N.

ZENNE

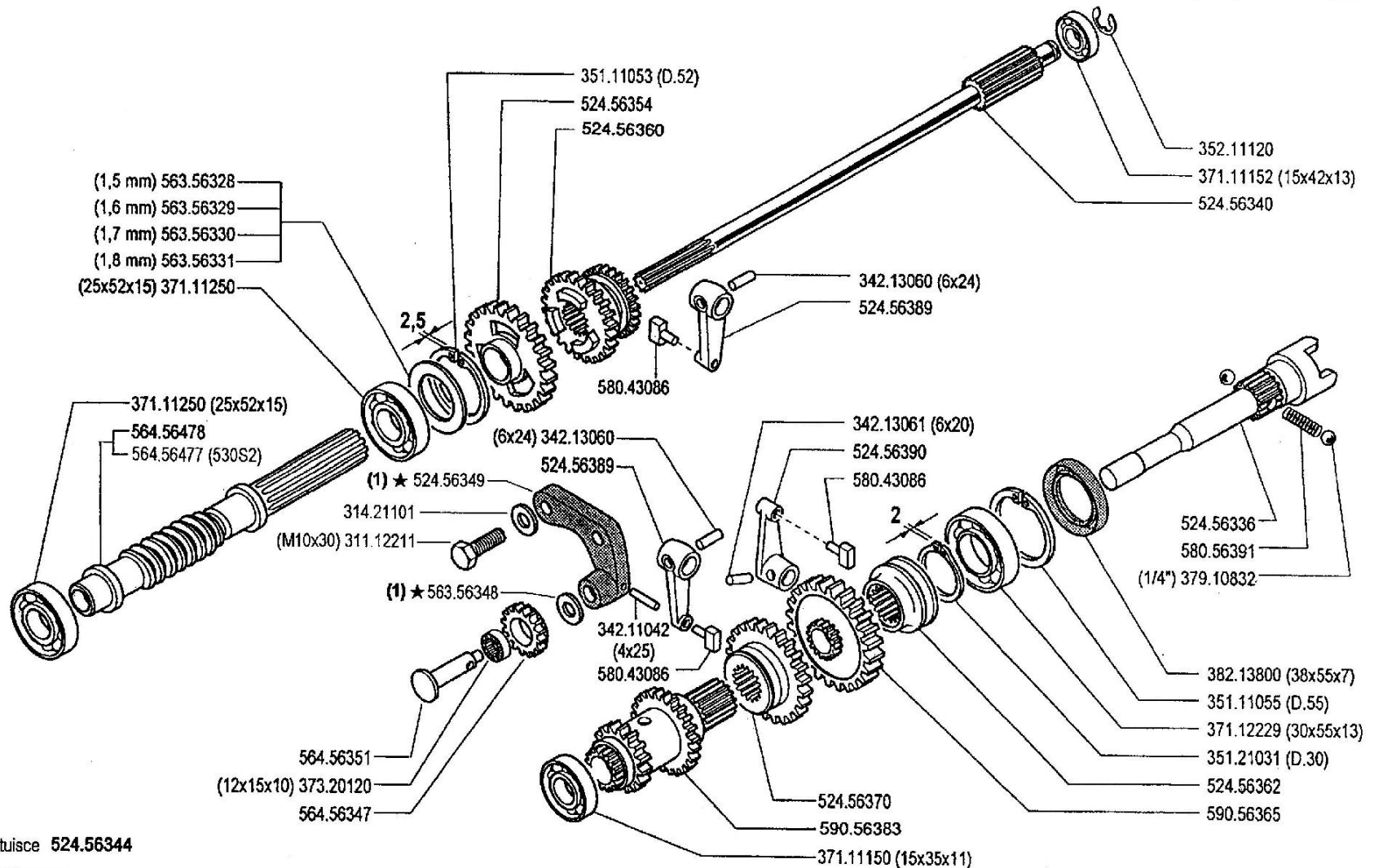

(1) sostituisce 524.56344

	<h1>500 serie 95</h1>	<b>INGRANAGGI CAMBIO (500 - 520 - 530 - 530S - 530S2) ★</b>		DALLA MACCHINA DE LA MAQUINA DE LA MACHINE FROM THE MACHINE AB DER MASCHINE	AGGIORNAMENTO	<h1>04</h1>	Rev.
		GEARS ENGRANAJES	ENGRANAGES ZAHNRÄDER		REVISION		2
				★N.	APLAZAMIENTO ANPASSUNG	<h1>9/2000</h1>	

ZENNE

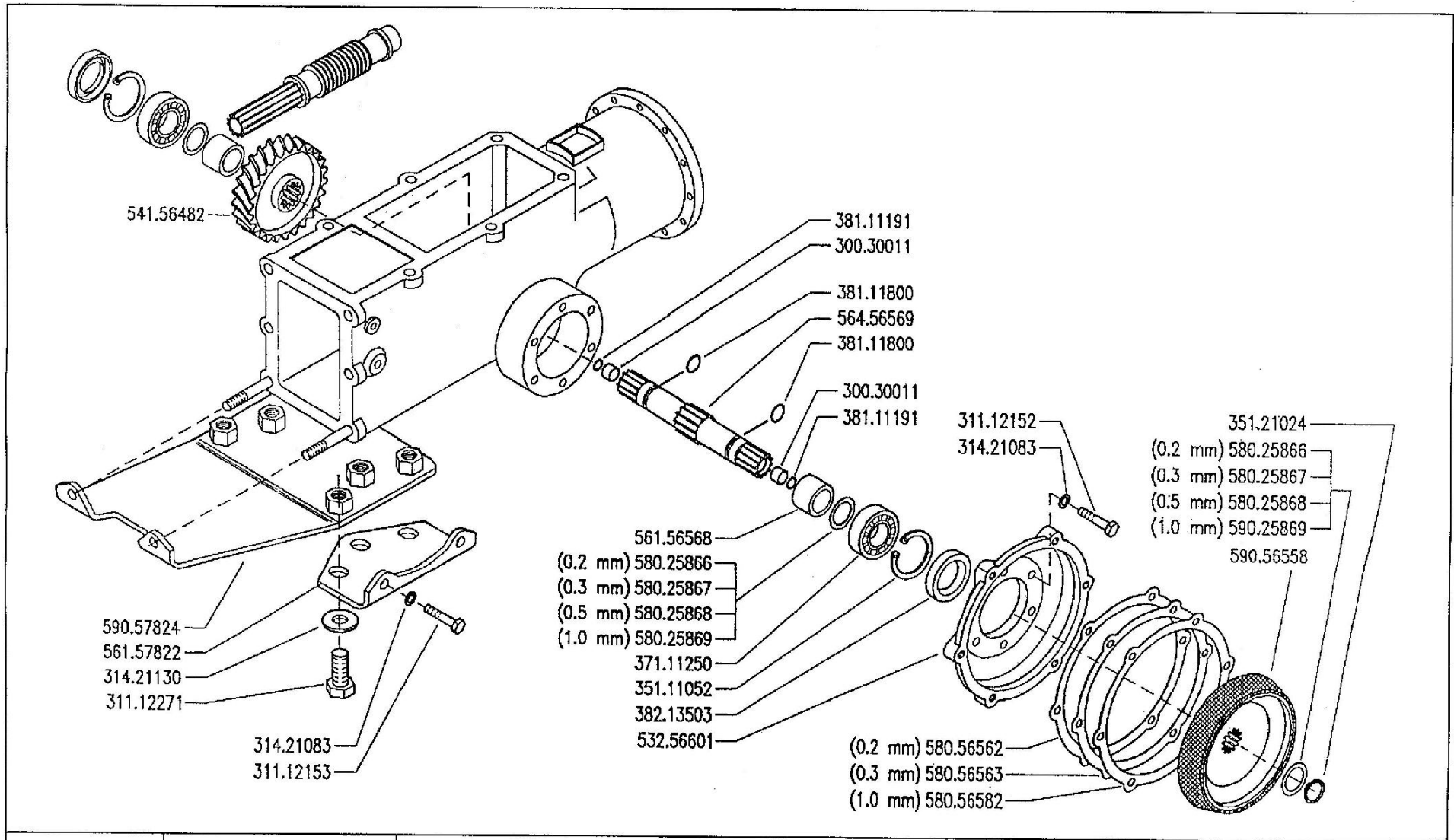

**FERRARI**

**500** serie 95

WHEEL AXLE  
EJE RUEDAS

**ASSE RUOTE (530S2)**

ESSIEU ROUES  
RADACHSE

DALLA MACCHINA  
DE LA MAQUINA  
DE LA MACHINE  
FROM THE MACHINE  
AB DER MASCHINE

N.

**05 C 0**

4/2003

Rev.

ZENNE

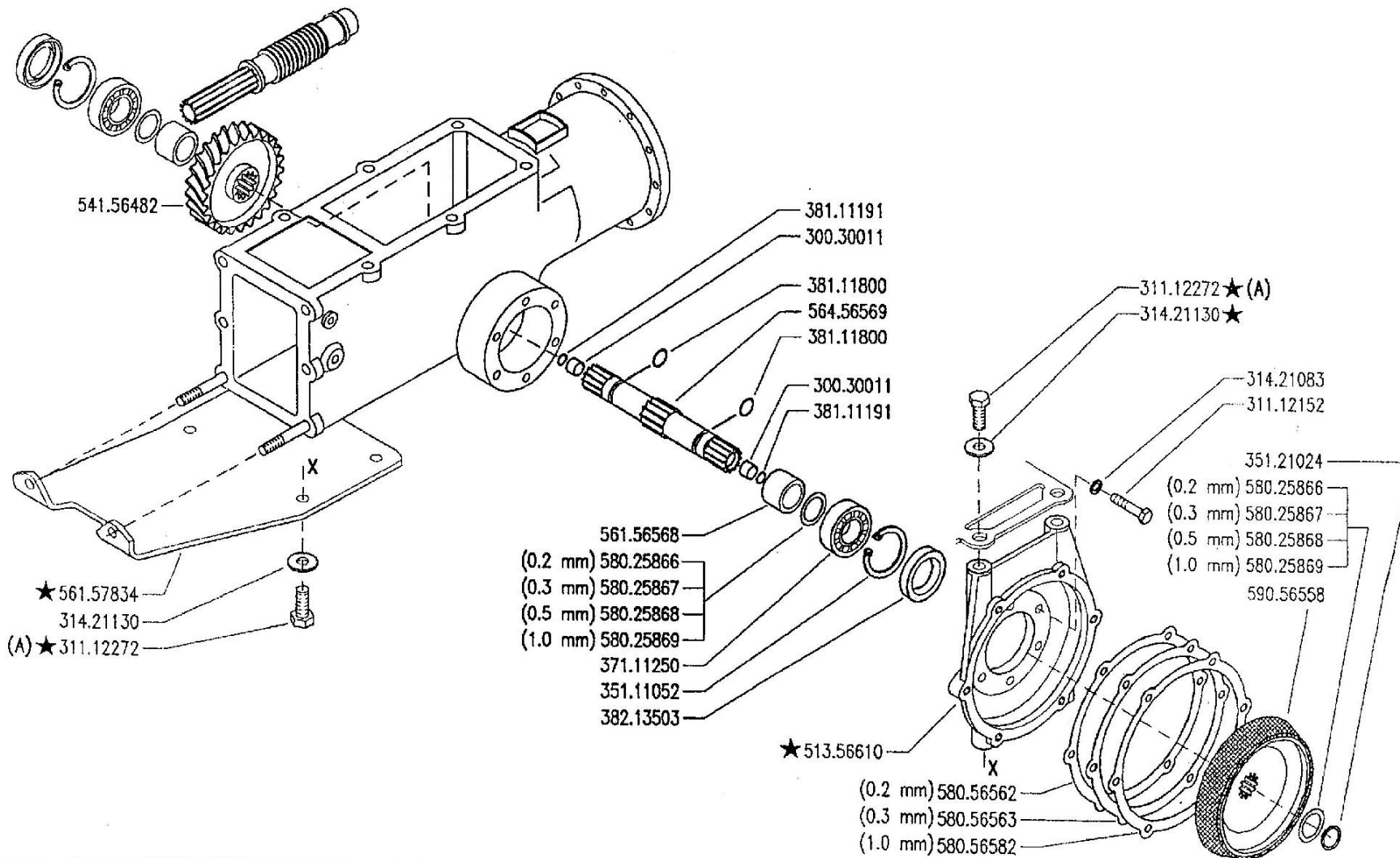

(A) serrare a 8.5 kgm

	<b>500</b> serie 95	WHEEL AXLE EJE RUEDAS	<b>ASSE RUOTE (530S2)</b>  ESSIEU ROUES RADACHSE	★ DALLA MACCHINA DE LA MAQUINA DE LA MACHINE FROM THE MACHINE AB DER MASCHINE	ALLA MACCHINA A LA MAQUINA A LA MACHINE TO THE MACHINE BIS MASCHINE	<b>05 C</b>	Rev. 1
				N. 721207 721255	721222		

ZENNE







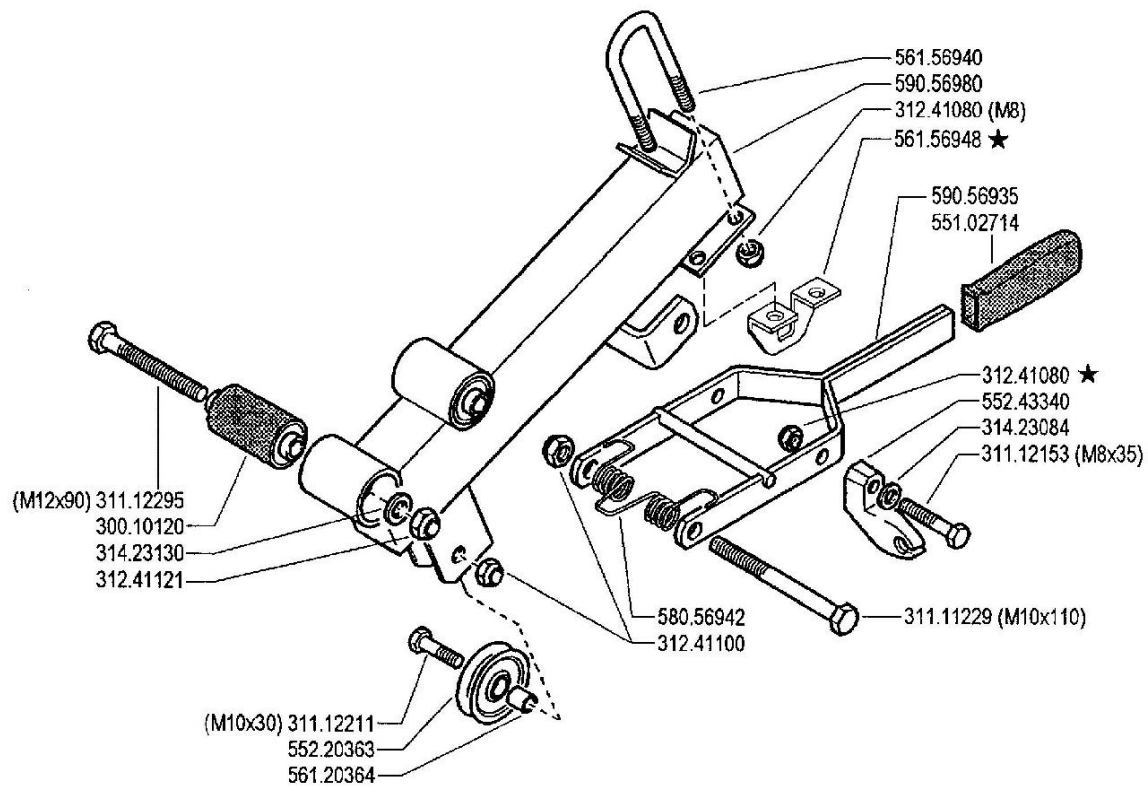

**FERRARI**

**500** serie **95**

**PIANTONE (500 - 510 - 520 - 530 - 530S - 530S2)**

STEERING COLUMN  
COLUMNNA

PLANTON  
LENKSÄULE

DALLA MACCHINA  
DE LA MAQUINA  
DE LA MACHINE  
FROM THE MACHINE  
AB DER MASCHINE

★N

AGGIORNAMENTO

REVISION

MISE A JOUR

APLAZAMIENTO

ANPASSUNG

**07**

**12/2002**

Rev.

**3**

ZENNE

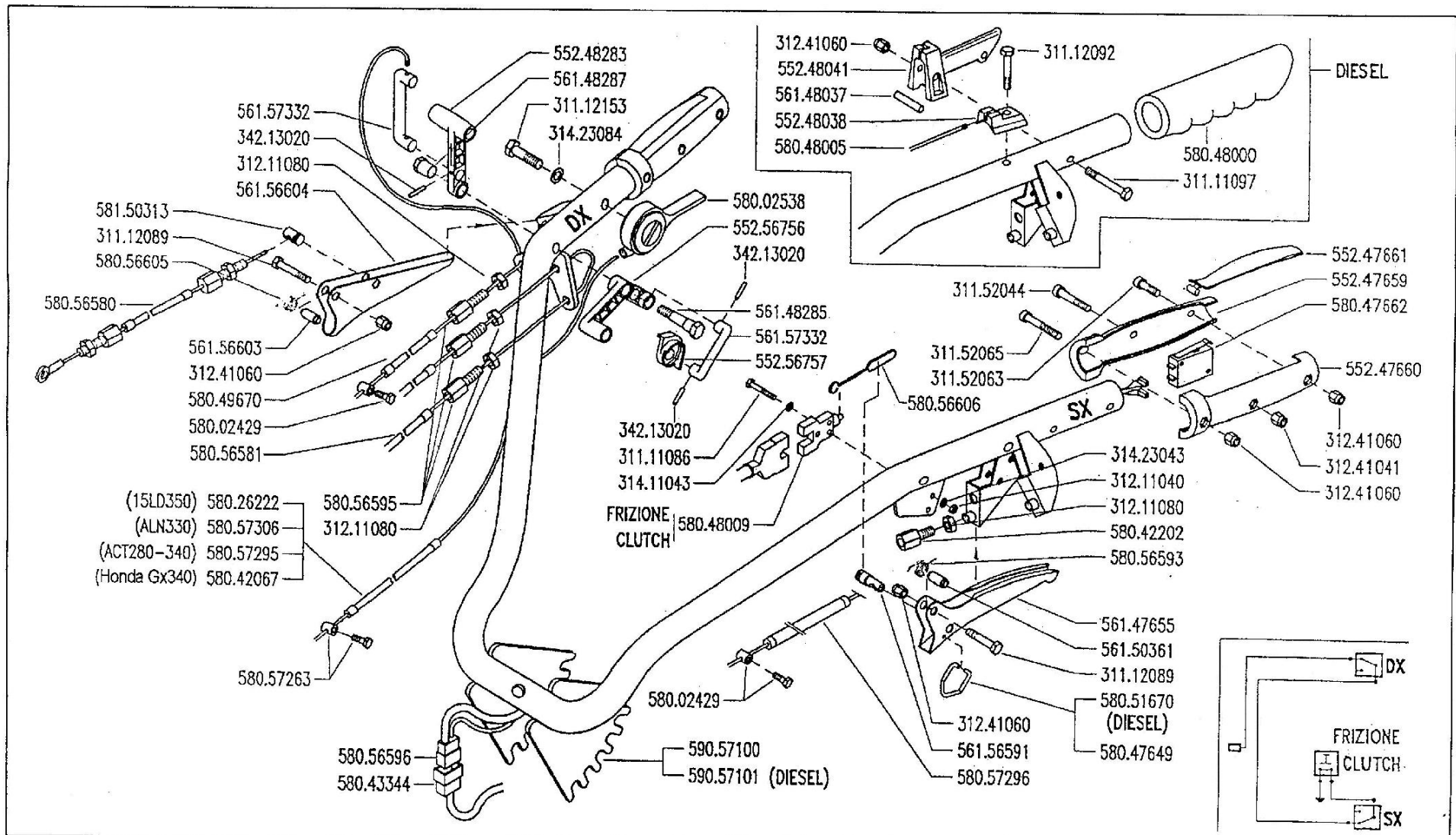

**FERRARI**

**500 serie 95**

HANDLEBAR (530S2)  
MANILLAR (530S2)

**MANUBRIO (530S2)**

MANCHERON (530S2)  
LENKER (530S2)

DALLA MACCHINA  
DE LA MAQUINA  
DE LA MACHINE  
FROM THE MACHINE  
AB DER MASCHINE

N.

**08 C 0**

**12/2002**

Rev.

LENNE

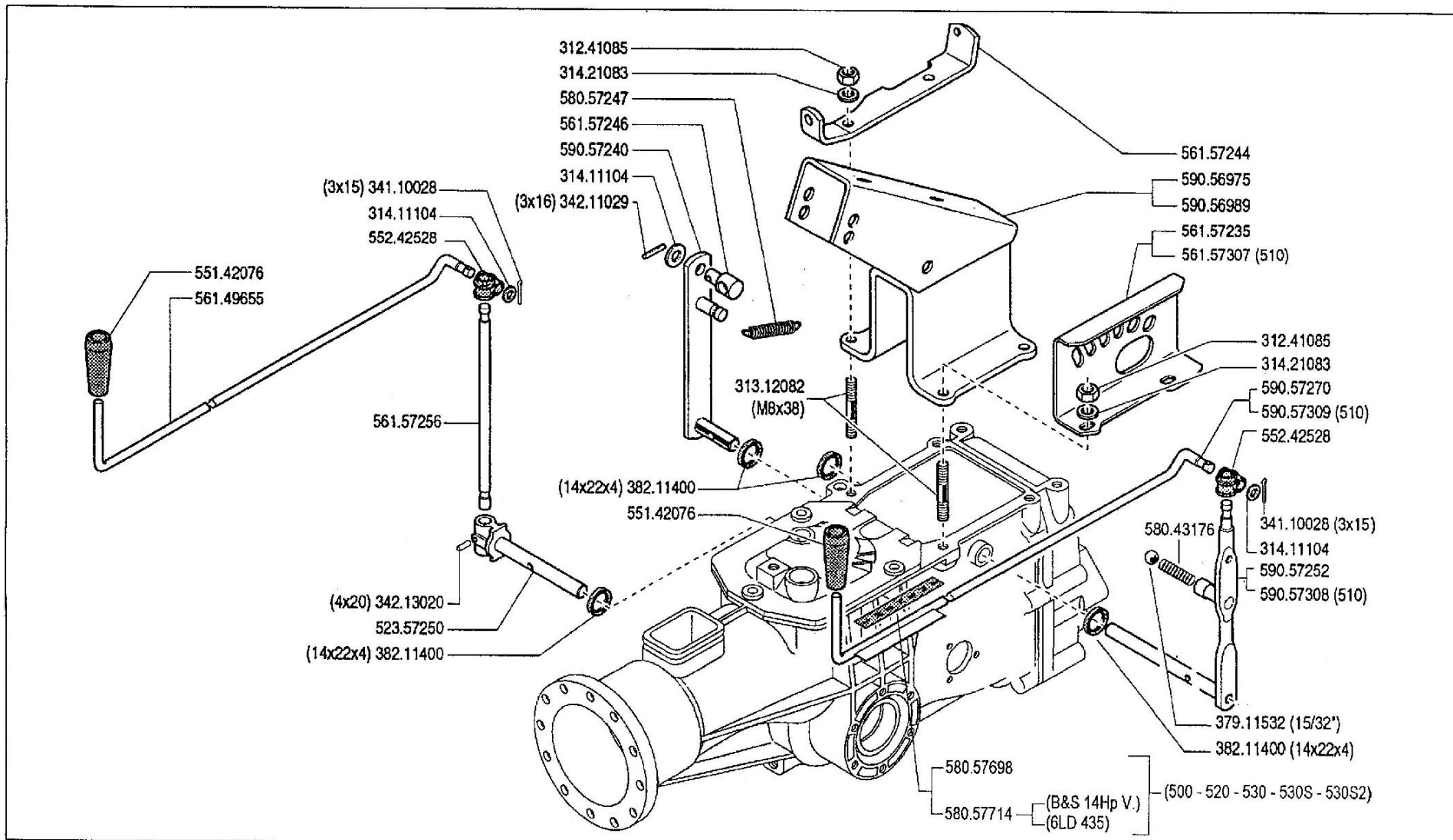

**FERRARI**

**500** serie **95**

**COMANDI (500 - 510 - 520 - 530 - 530S★ - 530S2★)**

CONTROLS  
MANDOS

COMMANDES  
ANTRIEBE

DALLA MACCHINA  
DE LA MAQUINA  
FROM THE MACHINE  
AB DER MASCHINE

AGGIORNAMENTO

REVISION

MISE A JOUR

APLAZAMIENTO

ANPASSUNG

**09**

Rev.  
**3**

**10/2001**

★N

ZENNE

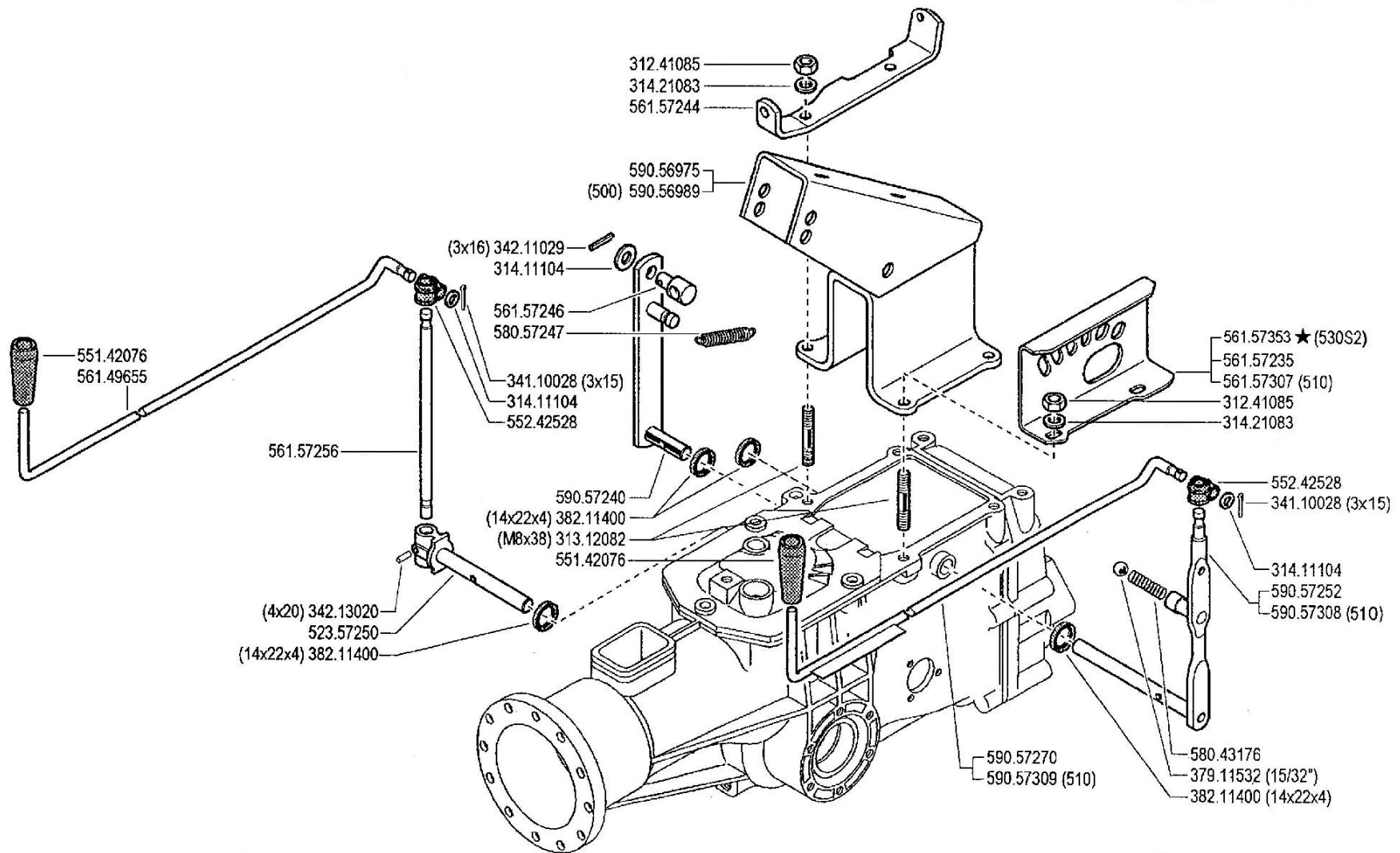

**FERRARI**

**500** serie **95**

**COMANDI (500 - 510 - 520 - 530 - 530S2)**

CONTROLS  
MANDOS

COMMANDES  
ANTRIEBE

★ DALLA MACCHINA  
DE LA MAQUINA  
DE LA MACHINE  
FROM THE MACHINE  
AB DER MASCHINE

ALLA MACCHINA  
A LA MAQUINA  
A LA MACHINE  
TO THE MACHINE  
BIS MASCHINE

**09**

Rev.  
**4**

N. 721207  
721255

721222

1/2004

ZEMME

	A	B	C
3.50 - 8" (500)	391.13502	394.13502	580.52325
3.50 - 8"	391.13502	394.13502	580.52326
4.00 - 8"	391.14008	394.14008	580.52326
4.0 - 10"	391.14010	394.14010	580.52327
5.0 - 10"	391.15010	394.15010	580.52327
21 x 11.00 - 8"	391.13501	TUBELESS	580.52274 ★ (1)

★ 924.57794

KIT GEMELLAGGIO PER 4.0-10" / 5.0-10"  
 TWINNING KIT FOR 4.0-10" / 5.0-10"  
 JUMELAGE KIT POUR 4.0-10" / 5.0-10"  
 KIT GEMELOS POR 4.0-10" / 5.0-10"  
 ZWILLINGSKIT 4.0-10" / 5.0-10"

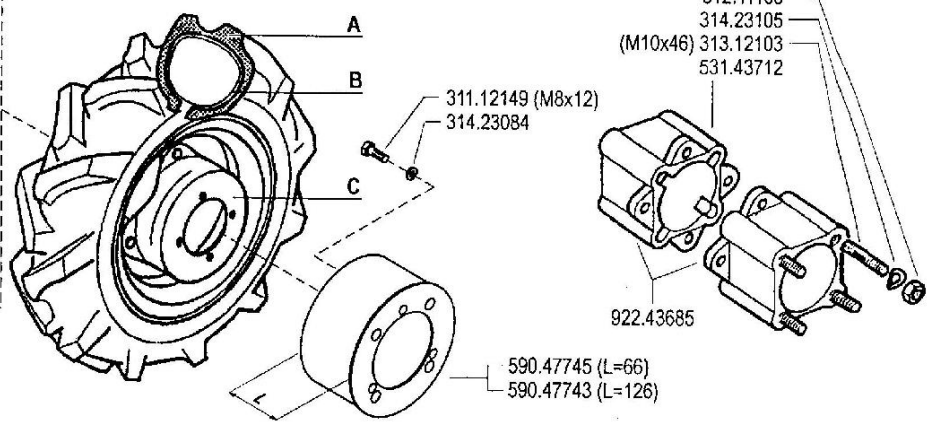
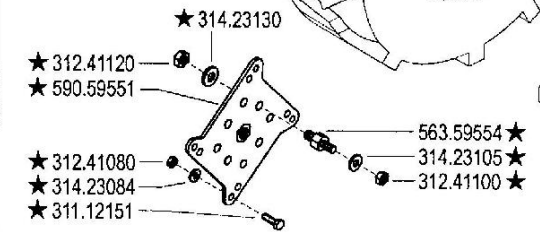
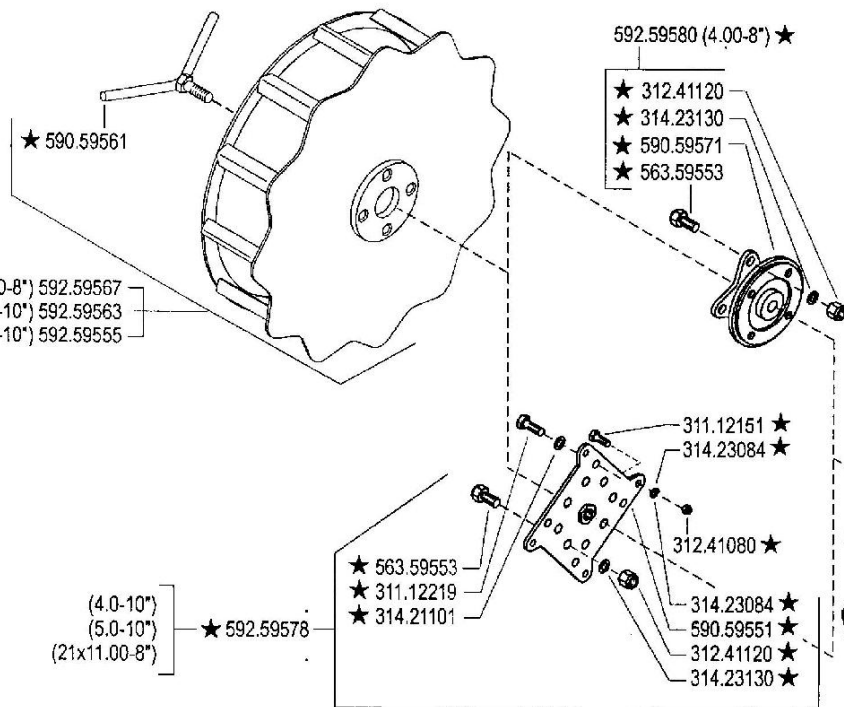
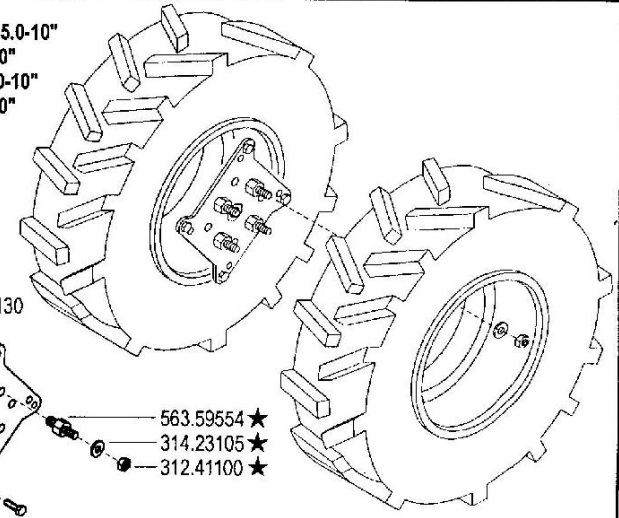

- ★ (4.00-8") 592.59567
- ★ (4.0-10") 592.59563
- ★ (5.0-10") 592.59555

- (4.0-10")
- (5.0-10")
- (21x11.00-8")
- ★ 592.59578

- ★ 563.59553
- ★ 311.12219
- ★ 314.21101
- ★ 311.12151
- ★ 314.23084
- ★ 312.41080
- ★ 314.23084
- ★ 590.59551
- ★ 312.41120
- ★ 314.23130

(1) sostituisce 580.52331

**FERRARI**

500 serie 95

RUOTE

WHEELS  
RUEDAS

ROUES  
RÄDER

DALLA MACCHINA  
DE LA MAQUINA  
DE LA MACHINE  
FROM THE MACHINE  
AB DER MASCHINE

AGGIORNAMENTO  
REVISION  
MISE A JOUR  
APLAZAMIENTO  
ANPASSUNG

11  
3  
12/2003

★N

ZENNE

510

580.52033

510

580.52034

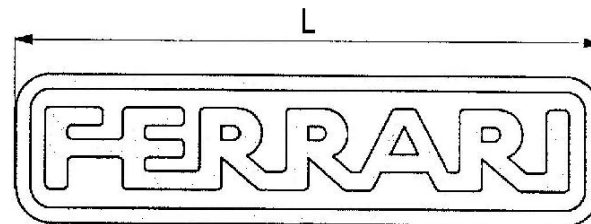

580.52019 (L= 87)  
580.52029 (L= 140)  
580.52020 (L= 174)

515

580.52144

515

580.52145

520

580.52021

520

580.52022

500

580.52018

530

580.52023

530

580.52024

515 L

580.52146

530 S

580.52150 ★

530 S

580.52151 ★

515 L

580.52147

530 S2

580.52154 ★

530 S2

580.52155 ★

515 S

580.52148

515 S

580.52149

FERRARI

500 serie 95

ADERIVI

STICKERS  
ADHESIVOS

AUTOCOLLANTS  
AUFKLEBES

DALLA MACCHINA  
DE LA MAQUINA  
DE LA MACHINE  
FROM THE MACHINE  
AB DER MASCHINE

AGGIORNAMENTO

REVISION

MISE A JOUR

APLAZAMIENTO

ANPASSUNG

12

Rev.  
2

10/2001

★N

ZENIT



580.57698

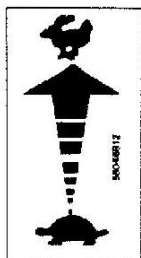

580.46912



580.46913



580.57772 ★



580.57771 ★



580.57767 ★

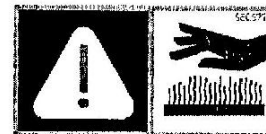

580.57768 ★



580.57678



580.57712



580.57676

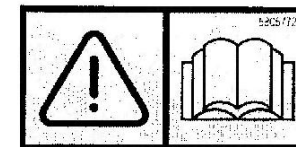

580.57724



580.57770 ★



580.57722

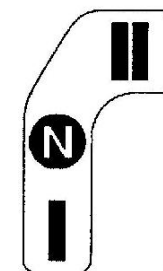

580.57732

FERRARI

500 serie 95

ADESIVI

STICKERS  
ADHESIVOS

AUTOCOLLANTS  
AUFKLEBES

DALLA MACCHINA  
DE LA MAQUINA  
DE LA MACHINE  
FROM THE MACHINE  
AB DER MASCHINE

AGGIORNAMENTO  
REVISION  
MISE A JOUR  
APLAZAMIENTO  
ANPASSUNG

13

Rev.  
1

12/2003

★N

ZENNE